

FIRE SAFETY ON BALCONIES

Important safety advice from the City of Melbourne and the Metropolitan Fire Brigade (MFB) to help reduce the risk of fires starting and spreading from balconies to exterior walls and adjoining apartments.

Please take the following actions immediately to ensure your safety and prevent property damage.

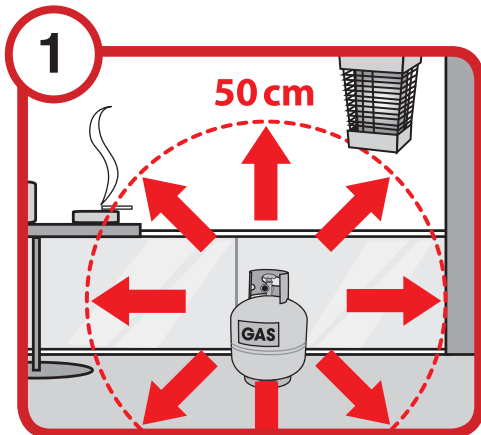

1 Always store gas bottles outside, upright and away from sources of heat.

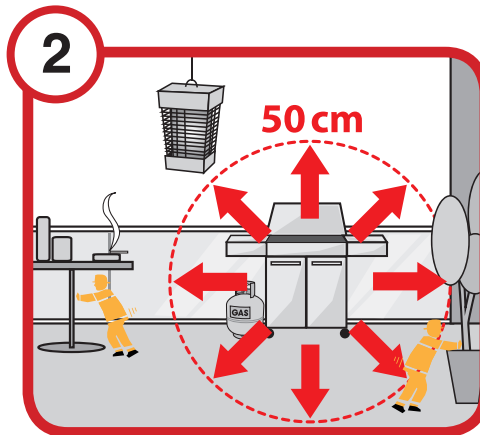

2 When using a barbeque maintain a safe distance of 50 cm from exterior walls, anything else that could burn, as well as any electrical ignition sources.



3 Smokers should use heavy, high-sided ashtrays (made of glass, ceramic or metal) to prevent them tipping over. Always fully extinguish cigarettes.

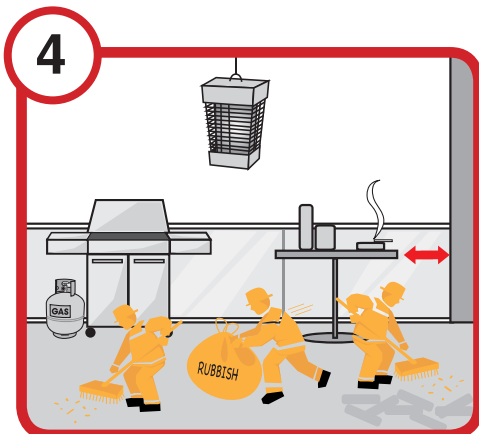

4 Remove rubbish, clutter and flammable items from balconies and keep furniture away from exterior walls.

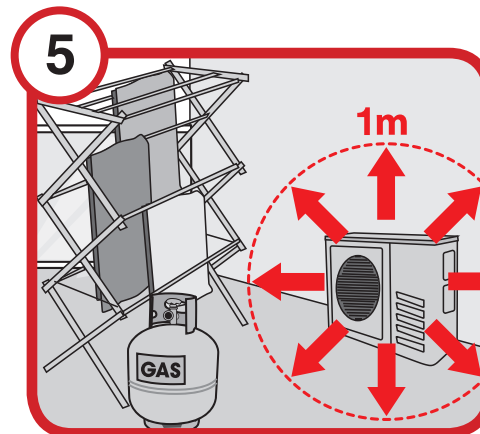

5 Keep goods, materials and clothes a safe distance of 1 metre clear of air conditioner units



6 Keep a dry powder fire extinguisher easily accessible. Use only in case of a small fire and if you feel physically and mentally able.

For further information on fire safety, MFB's Home Fire Safety booklet (accessible in English and 21 other languages) is available at: www.mfb.vic.gov.au

For further information on gas safety, visit the Energy Safe Victoria website at: www.esv.vic.gov.au

For Translating and Interpreting Service, contact 13 14 50.

In case of a fire, call 000 (triple zero)